

GAGGIA
Brera

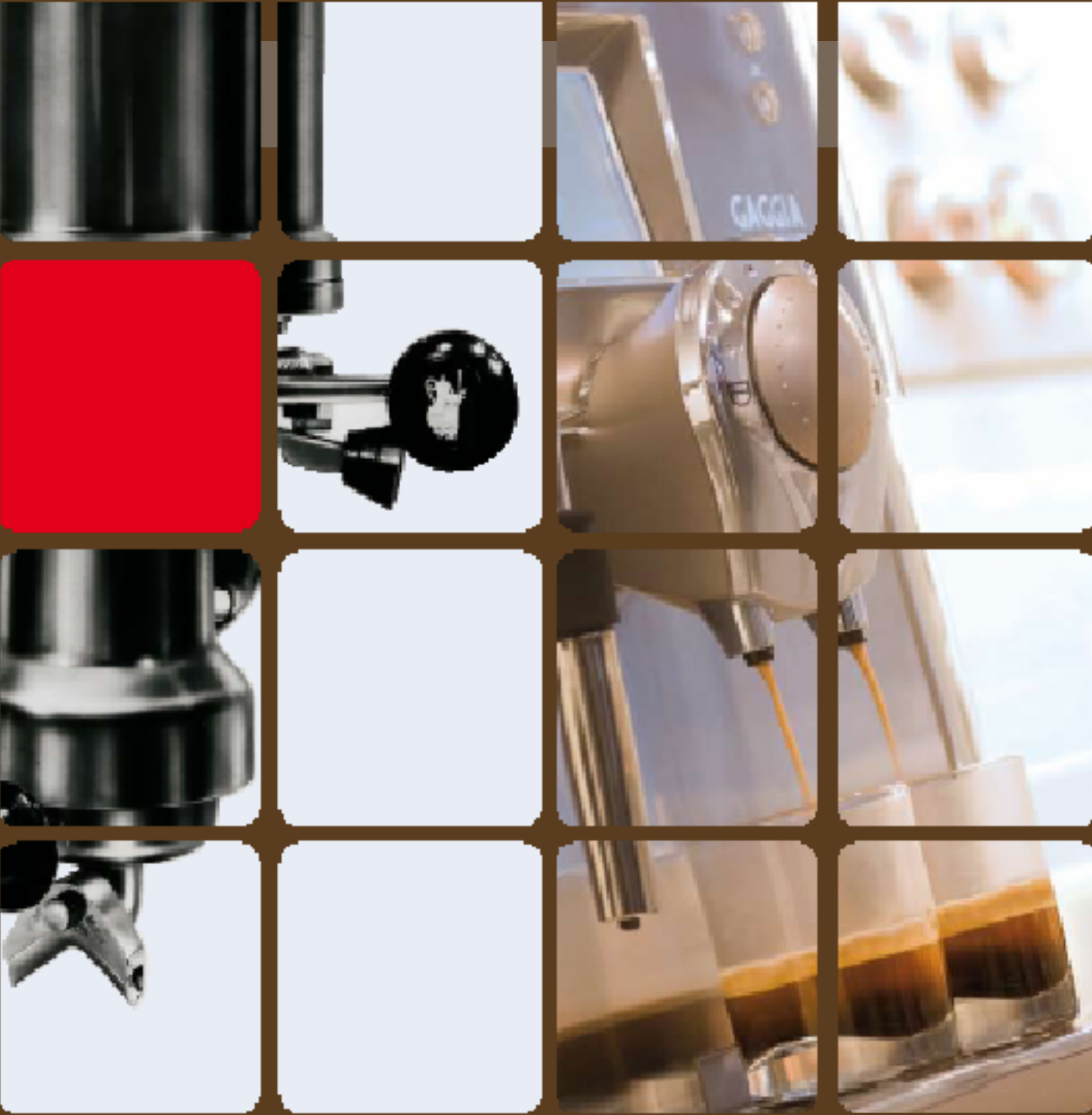

GAGGIA[®]
Tradizione In Continua Evoluzione

GAGGIA VALUES

GAGGIA
Brera

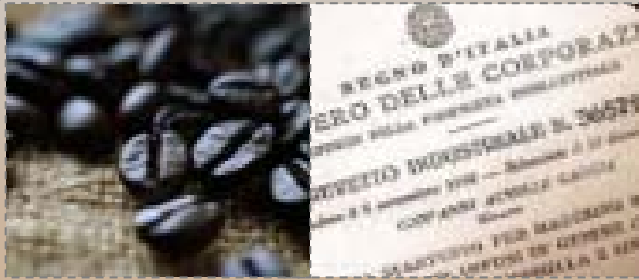

LONG ESPRESSO TRADITION

We extract the complete aroma from any coffee blend for an outstanding Espresso: a result of a long tradition professionally based.



AT HOME AS IN COFFEE SHOP

You don't have to go to coffee shop to taste an excellent Espresso. Gaggia, with its technology and experience, brings it to your homes.



EASY MULTIPLE CHOICE

Have from a real Espresso to creamy cappuccino at the push of a button. Become a coffee connoisseur.

GAGGIA[®]
Tradizione in Continua Evoluzione

GAGGIA VALUES

GAGGIA
Prera



TRADITION

All the Gaggia coffee machines are the result of a tradition of excellence that has lasted more than 70 years.



EMOTION

Delight the senses with a unique design of Gaggia espresso coffee machines together with a high quality Espresso coffee that they brew.



TIME TO RELAX

Pause and taste a cup of freshly brewed Espresso. Gaggia coffee machines will consent you to relax in a brief respite from the busy world.

GAGGIA
Tradizione in Continua Evoluzione

GAGGIA
Brera



The simplicity of a single touch

The tradition of Italian
Espresso

The unique pleasure of
a coffee break

All this is.....
GAGGIA BRERA

GAGGIA
Tradizione in Continua Evoluzione



Silver
Silver



black
black



NEW BRERA

GAGGIA
Brera

↳ **Compact design**

↳ **Attention to energy saving**

↳ **EASY interface**

↳ **Best espresso technologies**

↳ **Ground coffee doser**

↳ **Frontal Daily Maintenance**

↳ **High finishes**



GAGGIA[®]
Tradizione In Continua Evoluzione

BRERA – Compact Design

GAGGIA
Brera

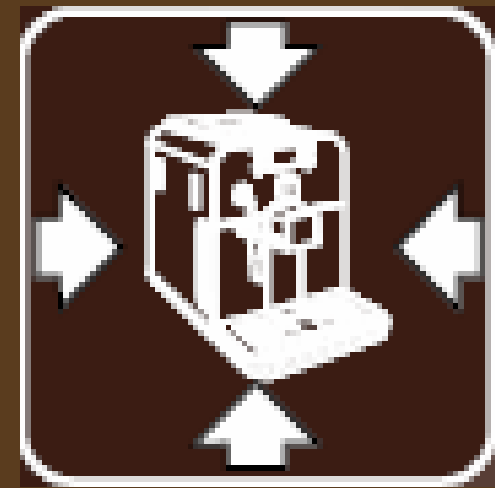
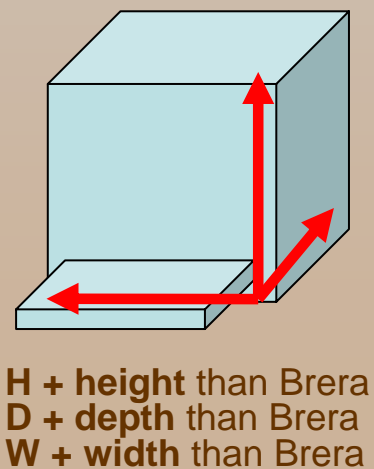
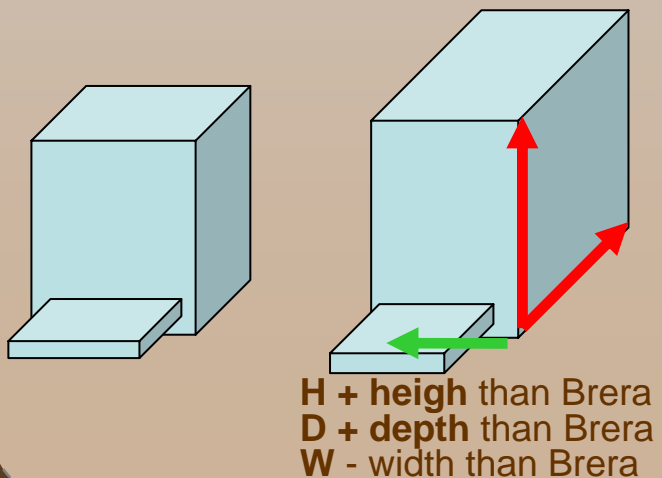
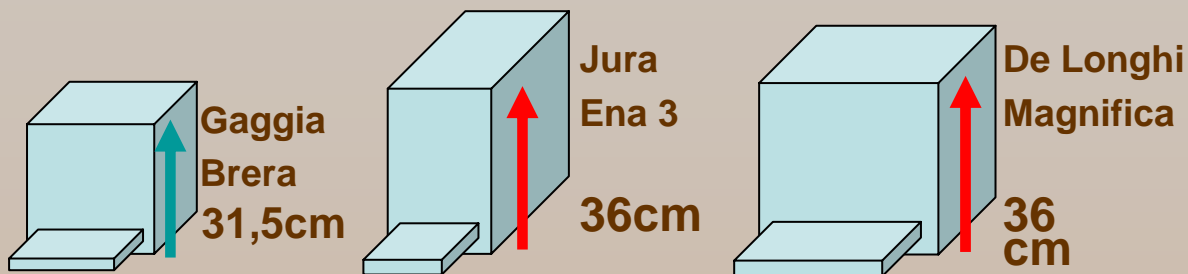

GAGGIA
Tradizione in Continua Evoluzione

BRERA – Energy Saving



“A” class energy label

➤ Automatic stand-by after 1h of non operation;
In stand-by the energy consumption is **< 1 W**



➤ According to Swiss voluntary regulation, to be fine-tuned and extended in the next years to all EU

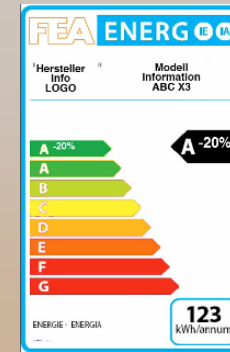

➤ Gaggia pays attention to sustainable development.



EASY INTERFACE

GAGGIA
Brera

☞ Coffee brewing: very easy interface, with 4 push-buttons and wide LED display with icons

☞ Cooler code for easy understanding:
Green → “ready to use”.
Orange → operations of customization and descaling cycle
Red → “blocking warnings”

☞ Central knob is dedicated to hot water and steam

☞ All functions are at the same level



GAGGIA
Tradizione in Continua Evoluzione

ESPRESSO IN 3 SIMPLE STEPS

GAGGIA
Breva

Switch on the machine
By pushing the on-off
button

1



When heating is finished
display shows following
icons.



Select Coffee Aroma
pushing Optidose or
pre-ground coffee
button

2



The display will show
From 1 to 3 beans or pre-
ground coffee icon



Select espresso or long
coffee by pushing the
related button (1-2
times for 1-2 coffee)

3



The display will show
if 1 or 2 coffees are
selected

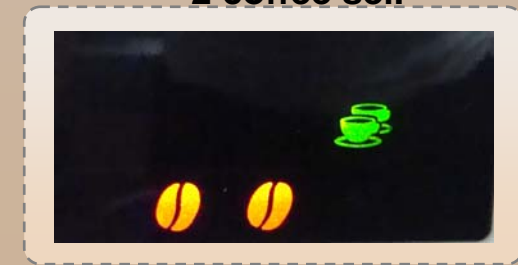

GAGGIA
Tradizione in Continua Evoluzione

EASY TO CUSTOMIZE

GAGGIA
Prera

• Coffe Aroma

OPTIDOSE function

Choose the right aroma

PRESS



= light aroma

= medium aroma

= strong aroma

o pre-ground coffee

• Coffe Length

Memorize the length of your Espresso
Or of the long coffee



Keep pressed the button until it reaches the desired dose to memorize your choice

• Espresso or Long coffee

Telescopic coffee dispenser adj.in height

H.max 110mm consent to use **small cup** or **mug**



GAGGIA
Tradizione in Continua Evoluzione

BRERA – pre-ground coffee Option

GAGGIA
Brera

☞ BRERA gives the possibility to use a pre-ground coffee / decaffeinated



- Pressing the on the display



button until the pre-ground coffee sign appears

GAGGIA[®]
Tradizione in Continua Evoluzione

EASY TO MAINTAIN

GAGGIA
Brera

- Simple use: all is accessible without moving the machine
- Immediate and frontal access to any key component
- All the elements normally used during **day-by-day operations** are completely **independent**

- ⌘ 1. Water tank
- ⌘ 2. Coffee grounds disposal
- ⌘ 3. Drip tray
- ⌘ 4. Coffee beans container

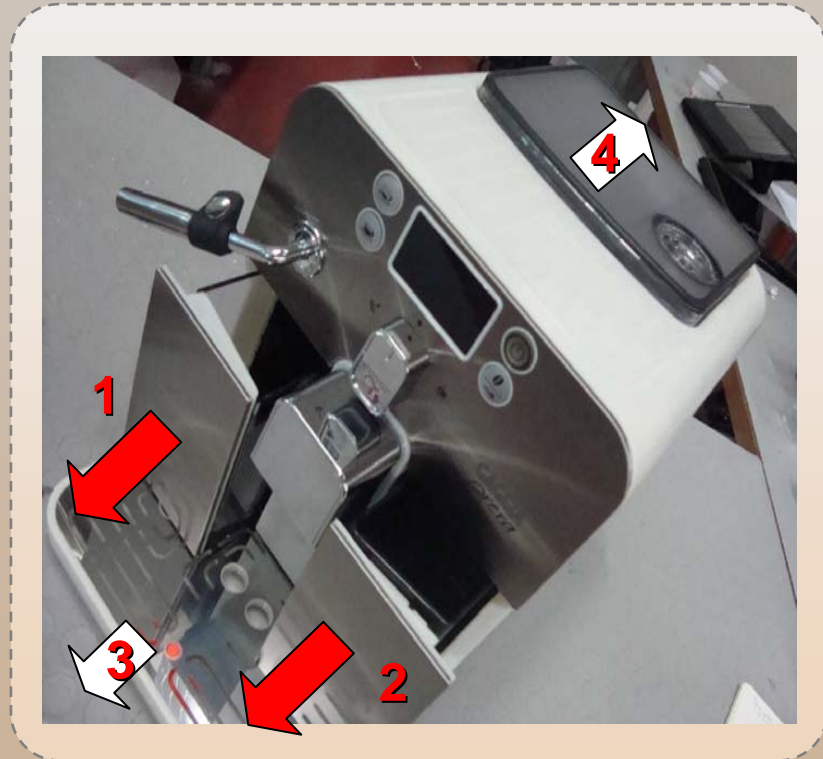

GAGGIA
Tradizione in Continua Evoluzione

EASY TO MAINTAIN

GAGGIA
Prera

The display will suggest any operation required to care for the machine and maintain it correctly. It will show a different icons to identify the problem.

Examples:

- ☞ Water in water tank missing;
- ☞ Empty dump containers
- ☞ Coffee beans missing.
- ☞ Return central knob to its position



GAGGIA
Tradizione in Continua Evoluzione

EASY TO CLEAN

GAGGIA
Brera

☞ The brewing group is at the heart of every fully automatic coffee machine and it should always be kept clean.

With GAGGIA's removable brewing group this operation has never been so easy:

Remove, rinse and re-insert.







GAGGIA[®]
Tradizione in Continua Evoluzione

BRERA – EASY TO MAINTAN

Rins/ Self-cleaning cycle

This cycle consents to rinse coffee circuits with fresh water to guarantee better performance and longer lifecycle of the machine.

-  during the switching on phase;
-  during the entering the stand-by mode (if a coffee has been brewed);
-  during the escaping the stand-by mode (only if the boiler is cold);
-  during the switching off phase.

DESCALING CYCLE

- the display informs you when descaling is necessary showing following icon
- the descaling is manual using the Gaggia descaling solution



BRERA – Precious finishes

GAGGIA
Brera

B Front panel in
STAINLESS STEEL

B Chrome plated finishes

B Cup plate in Stainless
steel

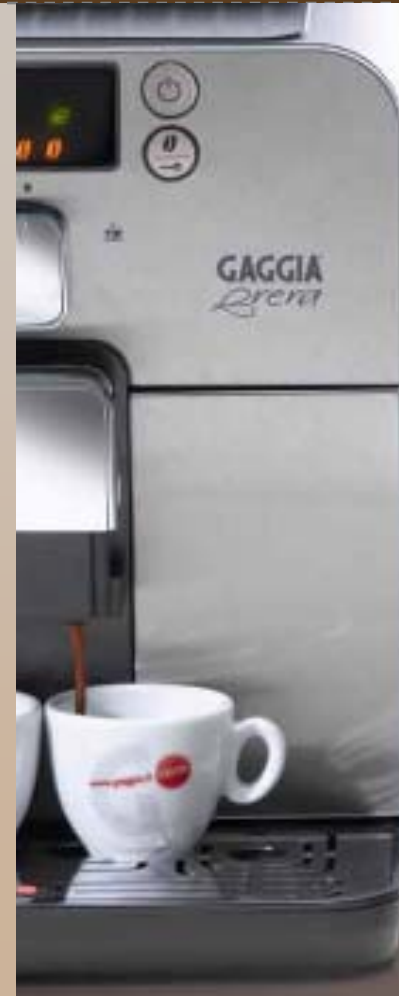

GAGGIA[®]
Tradizione in Continua Evoluzione

OUTSTANDING COFFEE AND AROMA

GAGGIA
Breva

The coffee taste is granted by the best preservation of coffee and the delicate grinding

✦ **Airtight and UV-proof coffee beans container**



✦ **Ceramic grinders** grant the most constant and most delicate grinding with no risk of overheating



✦ The Exclusive **Brita for Saeco** water filter ensures that only the purest water is used to brew coffee

GAGGIA
Tradizione in Continua Evoluzione

CERAMIC GRINDERS

long lasting performance to guarantee consistency in the grinding process and avoid any metal taste in the coffee; low temperature grinding and no risk of overheating the beans

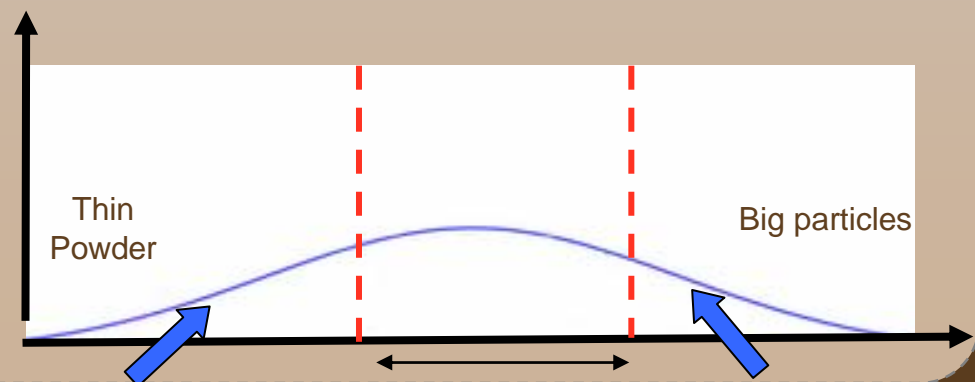
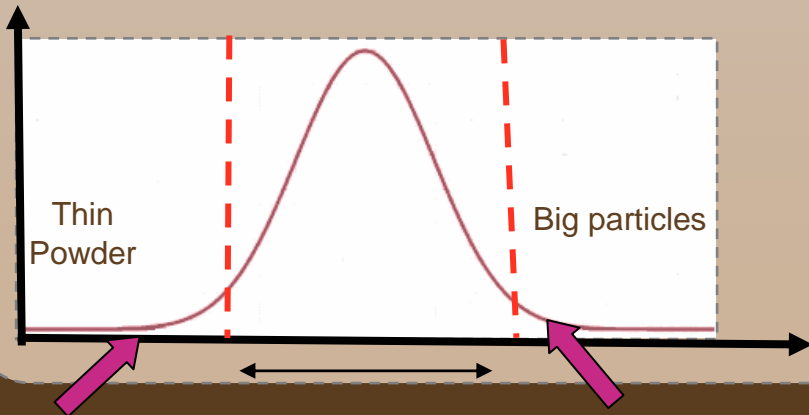
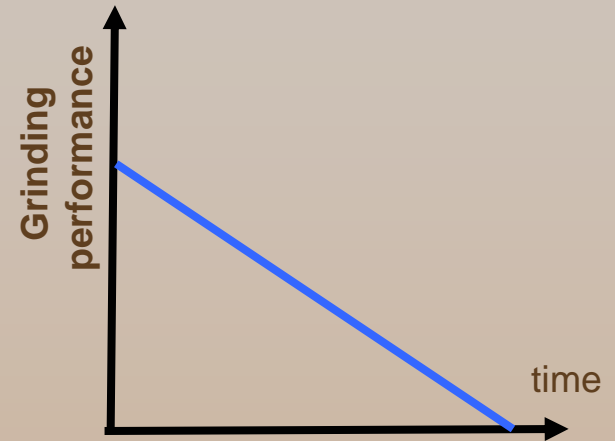
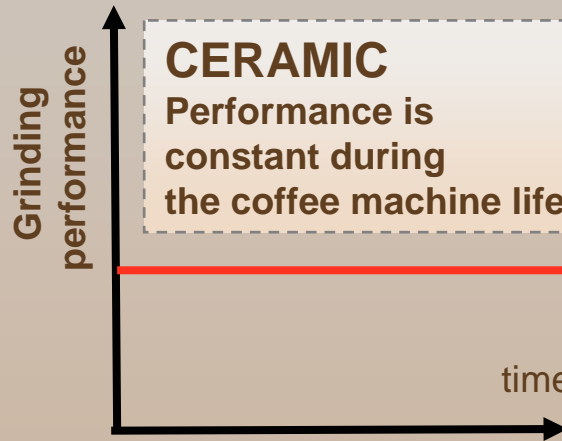

Very few coffee particles are outside the limits, which define the right size gap, to guaranteeing perfect consistency in the coffee table

GAGGIA Adapting System

Automatic adjustment of the grinding rpm to guarantee the selected quantity of ground coffee, independently from the coffee blend selected by the end user



Dark roasted coffee



Light roasted coffee

Thanks to the Gaggia Technology and the possibility to adjust the grinding degree (**), Gaggia guarantees to the end user the complete freedom to select his/her own preferred coffee blend

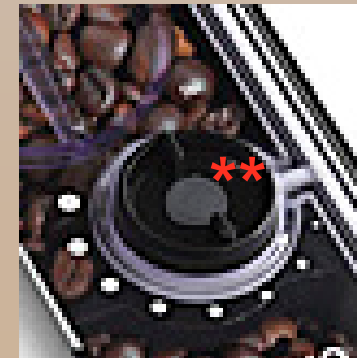

GAGGIA Adapting System

GAGGIA
Prera

Without GAS



Constant
RPM



Light roasted coffee



Constant
RPM



Different volume in the coffee powder, no possible to guarantee the aroma selected by the end user

With GAS



Rpm
adjustment



Light roasted coffee



Rpm
adjustment



Thanks to the rpm adjustment, we can guarantee the selected coffee powder amount with all the blends

GAGGIA
Tradizione in Continua Evoluzione

Pre-brewing System

GAGGIA
Prera

When you use the pre-brewing option, ground coffee is moistened with water and steeps for some time before the brewing process begins.

This helps to more fully extract flavor from the coffee grounds. In addition, pre moistening the coffee helps to avoid channeling, which is when the water finds only one or two paths through the coffee rather than evenly saturating it.



GAGGIA[®]
Tradizione in Continua Evoluzione

BRERA – OTHER PLUS

INTENZA WATER FILTER

Brera is equipped with Intenza filter with a 4 stages filtration system

- reduce hardness from the water that causes **scale** ;
- reduce chlorine content that can spoil the taste, smell and appearance of water
- keep impurities and other particles.

→ Optimize the overall quality and appearance of the coffee

→ Prolong machine life



GUARANTEE of MADE IN ITALY

GAGGIA and its Italian origin is synonymous with coffee competence, tradition and reliability the world over.

The Italian background is key to support the quality of the Espresso made with Brera and also to differentiate from most competitors.

BRERA has all the requisites to remark our Italian heritage and professional background.



NEW BRERA range

Technical Data

- ✧ Water tank: 1,2 l
- ✧ Coffee beans container: 250 g
- ✧ Coffee grounds container cap.: 8
- ✧ Material Finishing: full stainless steel
- ✧ Pump pressure: 15 bar
- ✧ Rated power input: 1400 W
- ✧ Power consumption in stand-by: <1W
- ✧ Weight: 8,5 kg
- ✧ Dimensions (wxhxd): 25,6x31,5x44,7
- ✧ Gaggia Adapting System
- ✧ Pre-brewing
- ✧ Optidose
- ✧ Coffee powder option
- ✧ Telescopic coffee dispenser
- ✧ Pannarello in metal
- ✧ 3 colors led display with icons
- ✧ Rapid Steam
- ✧ Grind regulation
- ✧ Ceramic grinder
- ✧ Manual Descaling cycle
- ✧ Water tank and dump box:
access from the front
- ✧ Removable brewing group (from
the side)

BRERA – POP MATERIALS



BTL: Catalogue & Leaflet



GAGGIA
Brera

La semplicità di un gesto.
La tradizione dell'espresso italiano da più di 70 anni.
Il piacere unico di una pausa caffè.
Tutto questo è GAGGIA Brera.

*The simplicity of a single touch.
More than 70 years of Italian Espresso tradition.
The unique pleasure of a coffee break.
All this is Gaggia Brera.*

GAGGIA
Tradizione in Continua Evoluzione



GAGGIA
Brera

La semplicità di un gesto.
La tradizione dell'espresso italiano da più di 70 anni.
Il piacere unico di una pausa caffè.
Tutto questo è GAGGIA Brera.

*The simplicity of a single touch.
More than 70 years of Italian Espresso tradition.
The unique pleasure of a coffee break.
All this is Gaggia Brera.*

GAGGIA
Tradizione in Continua Evoluzione